



EM PRODUCTS™

PHILLIPS & TEMRO INDUSTRIES

Engine Exhaust Silencers

Model JR Series Residential Grade

Standard Silencer Application

- Heavy-duty residential grade series silencer
- Designed for heavy duty stationary, marine systems and mobile power units
- JR Series silencers provide a moderate degree of silencing of exhaust noise from equipment used in residential areas

Standard Construction Features

- Aluminized steel standard for silencers up to 26 inch body diameter
- Silencers larger than 28 inch body diameter standard carbon steel
- All welded steel construction
- Can be mounted vertically or horizontally
- Standard high temperature (1200° F.) satin black finish
- Drains standard item
- Standard npt inlet and discharge connections on sizes 2 inch to 3.5 inch
- Standard 125/150# ASA drilled plate flanges on inlet and discharge of silencers 4 inch and larger
- Two-chamber design

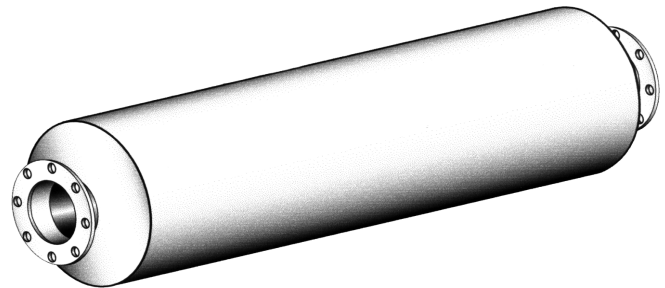

Optional Construction Features and Accessories

- Stainless steel and aluminum construction
- Special inlet and outlet connections
- Special inlet and outlet locations
- Special finishes available
- Vertical mounting legs
- Horizontal mounting saddles
- Mounting bands
- Horizontal and vertical shell legs
- Special acoustical designs
- Internal and external shell lagging
- Inspection openings
- Air leak tests
- ASME code construction
- Complete line of engine exhaust accessories

**REPRESENTATIVE ATTENUATION CURVE
FOR "JR" SERIES SILENCER**

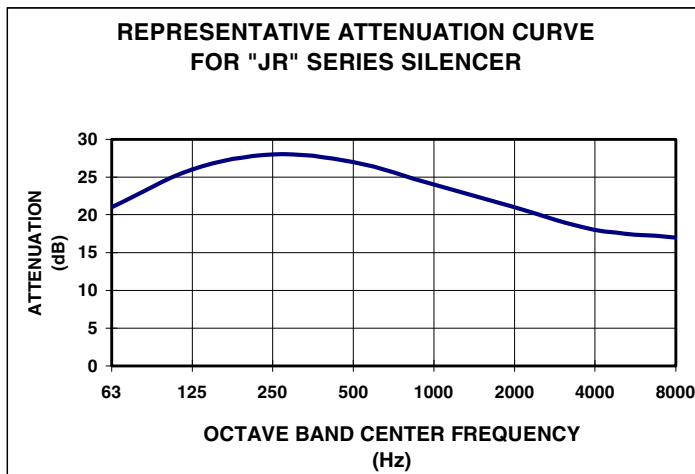

Engine Exhaust Silencer & Accessories:

- | | |
|-------------------|--------------------|
| 1. Silencer | 5. Mitered Exhaust |
| 2. Flex Connector | 6. Elbows |
| 3. Mounting Band | 7. Flange / Gasket |

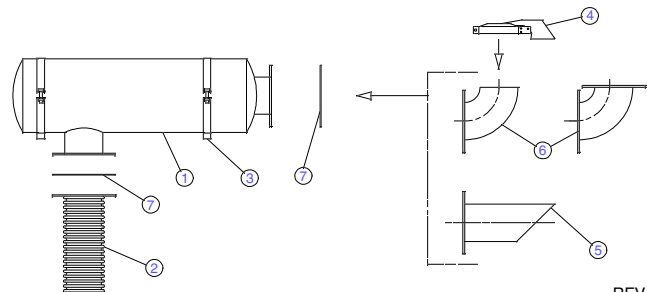

REV. 01/99
99EC-1000



Engine Exhaust Silencers

Model JR Series – Residential Grade

Average Attenuation Curve: 18 – 25 dBA

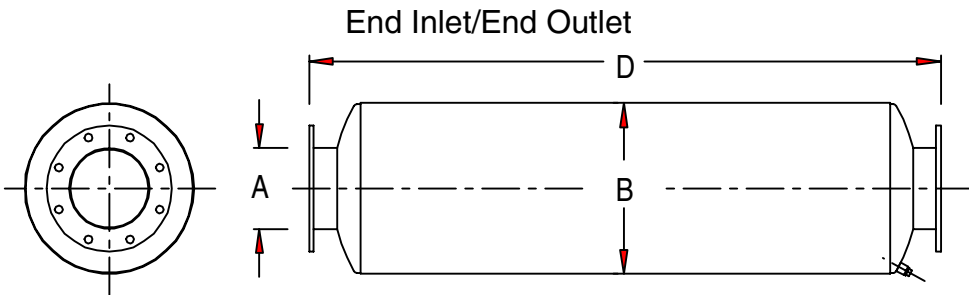

1 1/2 inch to 3 1/2 inch standard with male NPT connections; 4 inch and larger standard with 125/150# ANSI drilled plate flange connections.

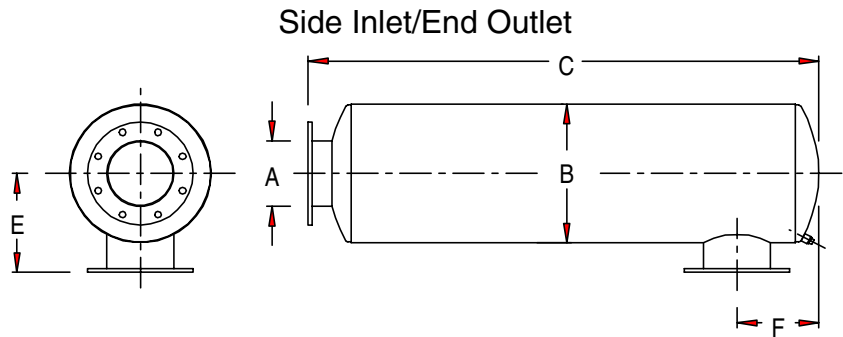

End Inlet/End Outlet					
Model No.	Part No.	A	B	D	WT
JRE-15	500070	1.5	6	24	8
JRE-02	500071	2	6	30	17
JRE-25	500072	2.5	8	30	24
JRE-03	500073	3	8	31	26
JRE-35	500074	3.5	10	43	42
JRE-04	500075	4	10	44	44
JRE-05	500076	5	12	56	75
JRE-06	500077	6	12	56	75
JRE-08	500078	8	18	68	155
JRE-10	500079	10	22	84	220
JRE-12	500080	12	26	96	325
JRE-14	500081	14	30	120	505
JRE-16	500082	16	36	136	870
JRE-18	500083	18	42	138	1280
JRE-20	500084	20	48	143	1700

Side Inlet/End Outlet							
Model No.	Part No.	A	B	C	E	F	WT
JRS-15	600180	1.5	6	21.75	5	2.75	8
JRS-02	600181	2	6	28	5.5	3	17
JRS-25	600182	2.5	8	28.5	6.5	3.6	24
JRS-03	600183	3	8	29	7	4.1	26
JRS-35	600184	3.5	10	41	8	5	42
JRS-04	600185	4	10	41.5	8.5	5.5	44
JRS-05	600186	5	12	54	10	6.6	75
JRS-06	600187	6	12	54	10	7.6	75
JRS-08	600188	8	18	66.5	13	10.5	155
JRS-10	600189	10	22	81	15	15	220
JRS-12	600190	12	26	93.5	17	17.5	325
JRS-14	600191	14	30	118	19	20	505
JRS-16	600192	16	36	133	22	23	870
JRS-18	600193	18	42	135.5	25	31.5	1280
JRS-20	600211	20	48	139	28	35	1700

• Larger sizes available upon request.
 Dimensions in inches, weights in pounds. Dimensions and weights are nominal and may vary slightly with production models.
 Request certified drawings for exact dimensions.