

EDWARDS MODEL 160 PUMPS

ROTARY GEAR PUMPS PUMP ONLY

DATED **APRIL 2009**

SUPERSEDES PAGE 201

DATED MAY 2005

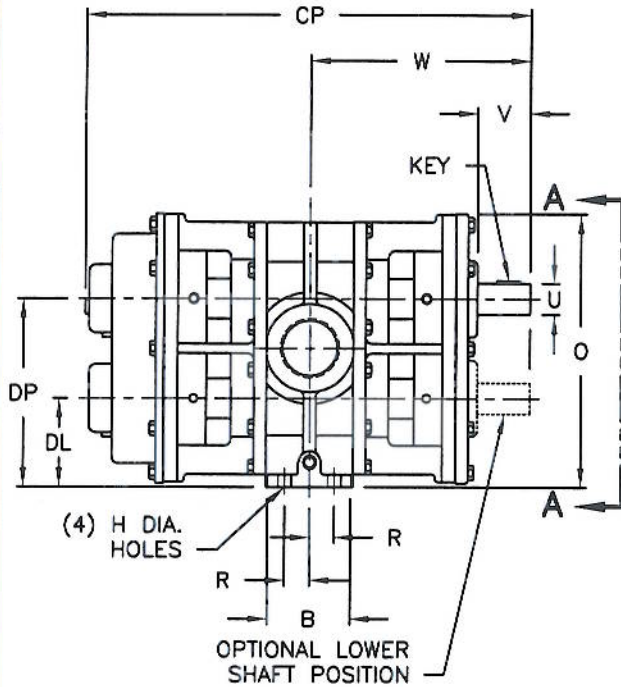

UPPER DRIVE

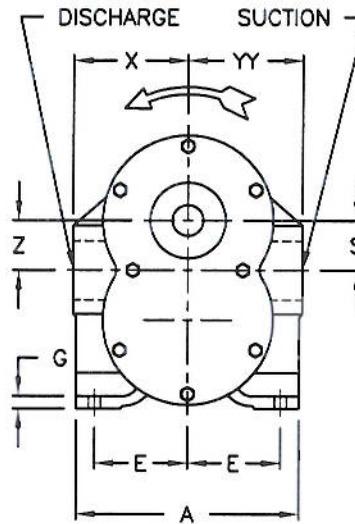

VIEW A-A
LEFT HAND
ROTATION

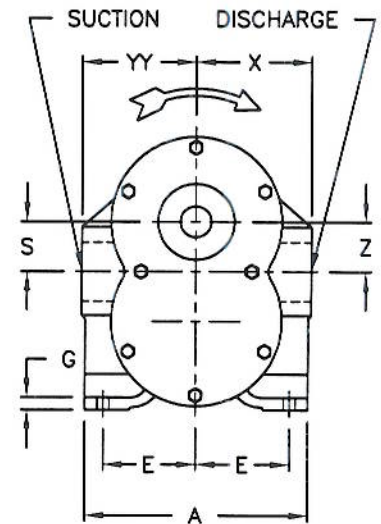

VIEW A-A
RIGHT HAND
ROTATION

LOWER DRIVE

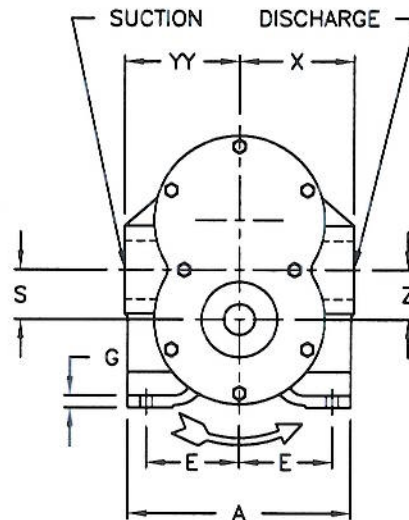

VIEW A-A
LEFT HAND
ROTATION

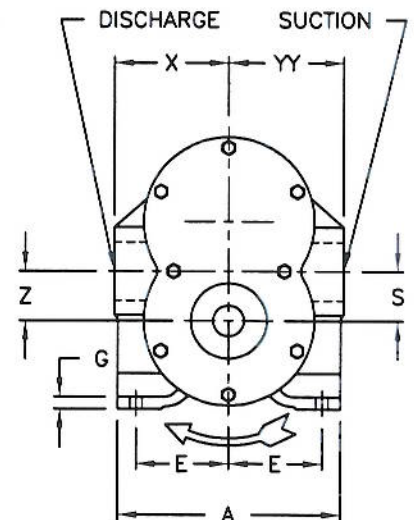

VIEW A-A
RIGHT HAND
ROTATION

NOTES:

1. All dimensions are in inches (mm).
2. Dimensions may vary $\pm .25"$ (6).
3. Not for construction purposes unless certified.
4. Discharge and suction ports are:
F-NPT (Female pipe threads)
5. Use the following notation for pump identification:
UR = UPPER SHAFT - RIGHT HAND ROTATION
UL = UPPER SHAFT - LEFT HAND ROTATION
LR = LOWER SHAFT - RIGHT HAND ROTATION
LL = LOWER SHAFT - LEFT HAND ROTATION

MODEL	DISCHARGE	SUCTION	A	B	CP	DL	DP	E	G	H
160	2" F-NPT	2" F-NPT	9.00 (229)	3.38 (86)	18.75 (476)	3.60 (91)	7.61 (193)	3.75 (95)	.50 (13)	.53 (13)

MODEL	O	R	S	U		V	W	X	YY	Z
				STANDARD	EXTRA HEAVY					
160	11.25 (286)	1.00 (25)	2.00 (51)	1.25 (32)	1.50 (38)	3.13 (80)	9.88 (251)	4.72 (120)	4.72 (120)	2.00 (51)
				KEY	KEY					
				1/4x7/8 WOODRUFF	3/8x1.50 SQ KEY					



EDWARDS MODEL 160 PUMPS

DATED APRIL 2009
 SUPERSEDES PAGE 202
 DATED MAY 2005

ROTARY GEAR PUMPS
 ELECTRIC MOTOR DRIVEN ON STANDARD STEEL BASE
 UPPER DRIVE

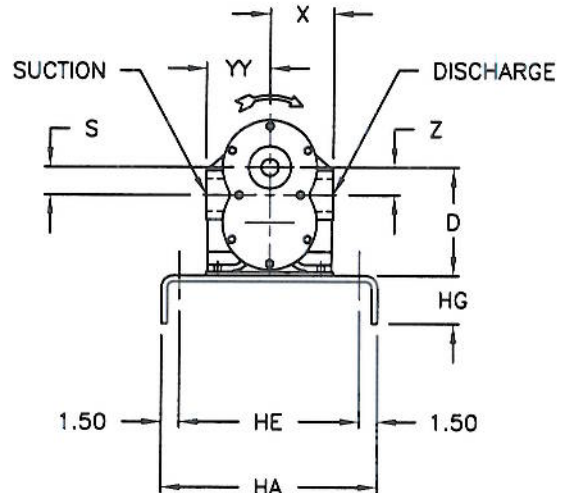
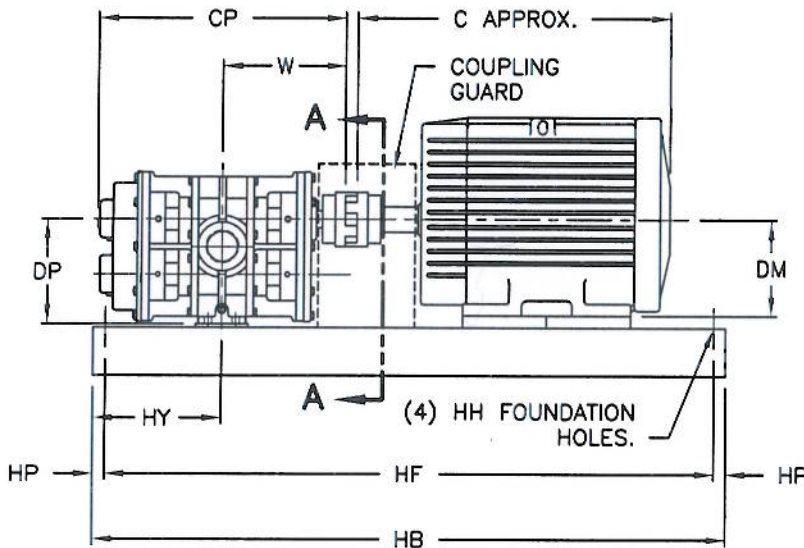

VIEW A-A
 RIGHT HAND
 ROTATION

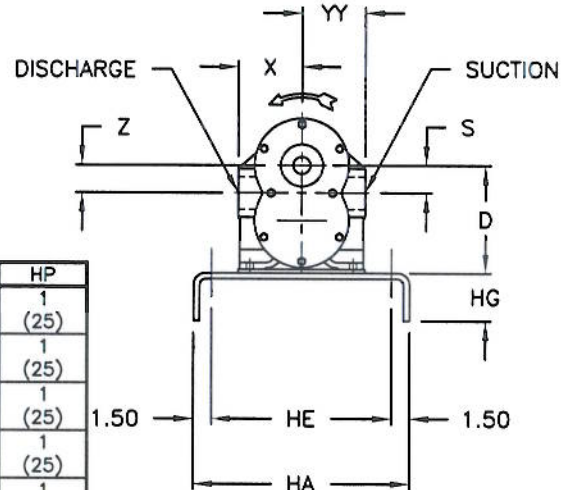

VIEW A-A
 LEFT HAND
 ROTATION

NOTES:

1. All dimensions are in inches (mm).
2. Dimensions may vary $\pm .25"$ (6).
3. Not for construction purposes unless certified.
4. Coupling gap may vary $.13"$ (3) to $2.06"$ (52).
5. Motor dimension "CP" is approximate. Motor dimensions are not specified as they vary with each motor manufacturer.
6. Discharge and suction ports are:
 F-NPT (Female pipe threads)
7. Use the following notation for pump identification:
 UR = UPPER SHAFT - RIGHT HAND ROTATION
 UL = UPPER SHAFT - LEFT HAND ROTATION

BASE NO.	SIZE	HA	HB	HE	HF	HG	HH	HP
4	13 X 42	13 (330)	42 (1067)	10 (254)	40 (1016)	4 (102)	.75 (19)	1 (25)
5	15 X 44	15 (381)	44 (1118)	12 (305)	42 (1067)	3.38 (86)	.75 (19)	1 (25)
6	15 X 48	15 (381)	48 (1219)	12 (305)	46 (1168)	3.38 (86)	.75 (19)	1 (25)
7	18 X 48	18 (457)	48 (1219)	15 (381)	46 (1168)	4 (102)	.75 (19)	1 (25)
8	18 X 54	18 (457)	54 (1372)	15 (381)	52 (1321)	4 (102)	.75 (19)	1 (25)
9	22 X 60	22 (559)	60 (1524)	19 (483)	58 (1473)	4 (102)	.75 (19)	1 (25)

MODEL	FRAME	254T	256T	284TS	284T	286TS	286T	324TS	324T	326TS	326T
	C	21 (533)	23 (584)	22 (559)	24 (610)	24 (610)	25 (635)	25 (635)	26 (660)	26 (660)	28 (711)
	DM	6.25 (159)	6.25 (159)	7.00 (178)	7.00 (178)	7.00 (178)	7.00 (178)	8.00 (203)	8.00 (203)	8.00 (203)	8.00 (203)
160	BASE NO.	4	4	5	5	6	6	7	7	7	7
	D	8.00 (203)	8.00 (203)	8.00 (203)	8.00 (203)	8.00 (203)	8.00 (203)	8.00 (203)	8.00 (203)	8.00 (203)	8.00 (203)

MODEL	FRAME	364TS	364T	365TS	365T	404TS	404T
	C	27 (686)	29 (737)	28 (711)	30 (762)	30 (762)	33 (838)
	DM	9.00 (229)	9.00 (229)	9.00 (229)	9.00 (229)	10.00 (254)	10.00 (254)
160	BASE NO.	8	8	8	8	9	9
	D	9.00 (229)	9.00 (229)	9.00 (229)	9.00 (229)	10.00 (254)	10.00 (254)

MODEL	DISCHARGE	SUCTION	CP	DP	HY	S	W	X	YY	Z
160	2" F-NPT	2" F-NPT	18.75 (476)	7.61 (193)	9.00 (229)	2.00 (51)	9.88 (251)	4.72 (120)	4.72 (120)	2.00 (51)



EDWARDS MODEL 160 PUMPS

ROTARY GEAR PUMPS ELECTRIC MOTOR DRIVEN ON STANDARD STEEL BASE LOWER DRIVE

DATED **APRIL 2009**

SUPERSEDES PAGE -

DATED -

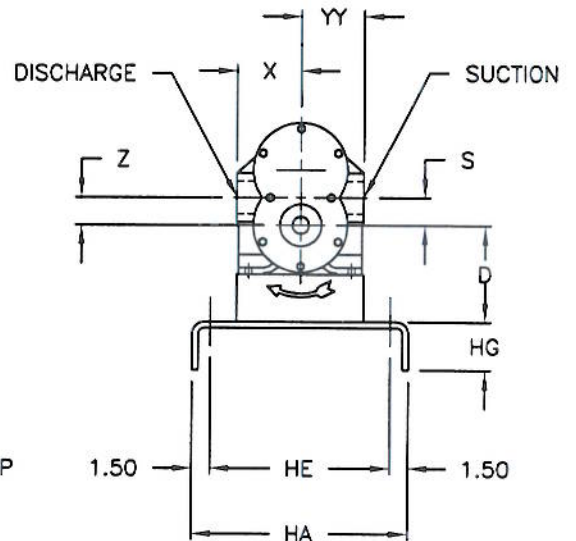
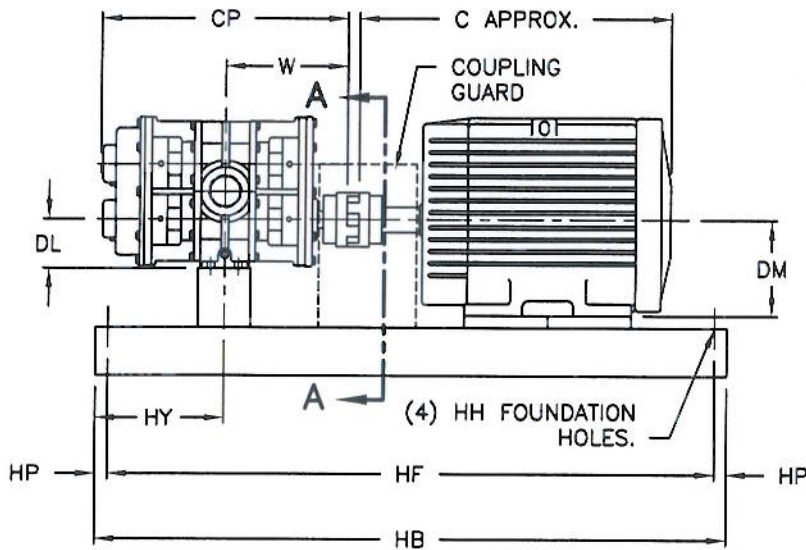

**VIEW A-A
RIGHT HAND
ROTATION**

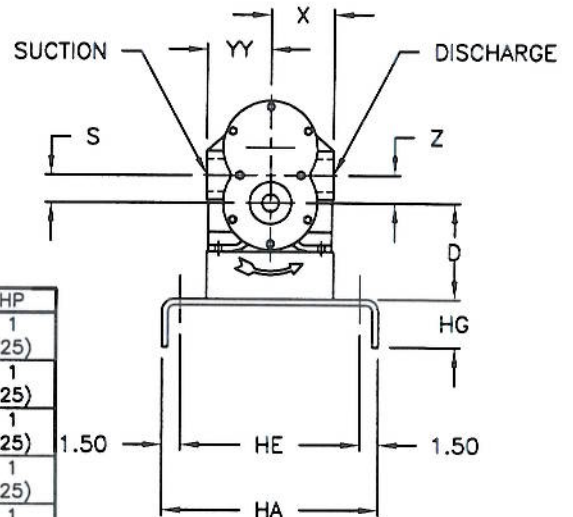

**VIEW A-A
LEFT HAND
ROTATION**

NOTES:

- All dimensions are in inches (mm).
- Dimensions may vary $\pm .25"$ (6).
- Not for construction purposes unless certified.
- Coupling gap may vary .13"(3) to 2.06"(52).
- Motor dimension "CP" is approximate. Motor dimensions are not specified as they vary with each motor manufacturer.
- Discharge and suction ports are:
F-NPT (Female pipe threads)
- Use the following notation for pump identification:
LR = LOWER SHAFT - RIGHT HAND ROTATION
LL = LOWER SHAFT - LEFT HAND ROTATION

BASE NO.	SIZE	HA	HB	HE	HF	HG	HH	HP
4	13 X 42	13	42	10	40	4	.75	1
		(330)	(1067)	(254)	(1016)	(102)	(19)	(25)
5	15 X 44	15	44	12	42	3.38	.75	1
		(381)	(1118)	(305)	(1067)	(86)	(19)	(25)
6	15 X 48	15	48	12	46	3.38	.75	1
		(381)	(1219)	(305)	(1168)	(86)	(19)	(25)
7	18 X 48	18	48	15	46	4	.75	1
		(457)	(1219)	(381)	(1168)	(102)	(19)	(25)
8	18 X 54	18	54	15	52	4	.75	1
		(457)	(1372)	(381)	(1321)	(102)	(19)	(25)
9	22 X 60	22	60	19	58	4	.75	1
		(559)	(1524)	(483)	(1473)	(102)	(19)	(25)

MODEL	FRAME	254T	256T	284TS	284T	286TS	286T	324TS	324T	326TS	326T
	C	21	23	22	24	24	25	25	25	26	26
		(533)	(584)	(559)	(610)	(610)	(635)	(635)	(660)	(660)	(711)
	DM	6.25	6.25	7.00	7.00	7.00	7.00	8.00	8.00	8.00	8.00
		(159)	(159)	(178)	(178)	(178)	(178)	(203)	(203)	(203)	(203)
160	BASE NO.	4	4	5	5	6	6	7	7	7	7
	D	6.25 (159)	6.25 (159)	7.00 (178)	7.00 (178)	7.00 (178)	7.00 (178)	8.00 (203)	8.00 (203)	8.00 (203)	8.00 (203)

MODEL	FRAME	364TS	364T	365TS	365T	404TS	404T
	C	27	29	28	30	30	33
		(686)	(737)	(711)	(762)	(762)	(838)
	DM	9.00	9.00	9.00	9.00	10.00	10.00
		(229)	(229)	(229)	(229)	(254)	(254)
160	BASE NO.	8	8	8	8	9	9
	D	9.00 (229)	9.00 (229)	9.00 (229)	9.00 (229)	10.00 (254)	10.00 (254)

MODEL	DISCHARGE	SUCTION	CP	DL	HY	S	W	X	YY	Z
160	2"	2"	18.75	3.60	9.00	2.00	9.88	4.72	4.72	2.00
	F-NPT	F-NPT	(476)	(91)	(229)	(51)	(251)	(120)	(120)	(51)

