

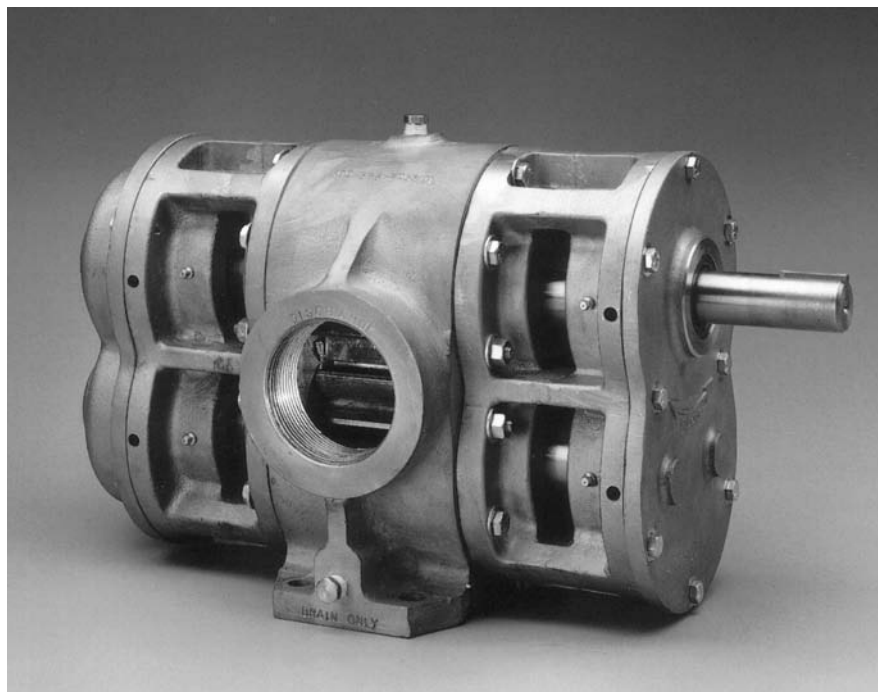

# MODEL 300 PUMP



## Features

The Edwards Model 300 Rotary Gear Pump has several unique features that make Edwards the right choice for many pumping requirements:

- Replaceable, casing liners
- Rotors synchronized by timing gears - they never touch
- Shafts are supported on both ends by bearings - not bushings
- Pump drive flexibility - direct drive in most cases
- Multiple materials of construction
- Dry running capability
- Inexpensive repairs
- Self priming

## Applications

### Fire Protection

- Fire-fighting foam concentrate
- Water mist pumps

### Industrial Applications

- High Pressure Solvents
- Fuel Oil
- Black Liquor Soap
- High Pressure Water
- Seawater or Brines
- Polymers, resins, glues
- Oils and Lubricants
- Deep Well Water Injection

## Industries Served

- Food processing (non-sanitary)
- Solvent/Pain processing
- Pulp and paper
- Fire Protection
- Marine fuel transfer
- General industrial
- Bulk transfer-trucking
- Mining
- Oil Field
- Truck wash systems

# MODEL 300 PUMP SPECIFICATIONS

## Approximate Overall Dimensions:

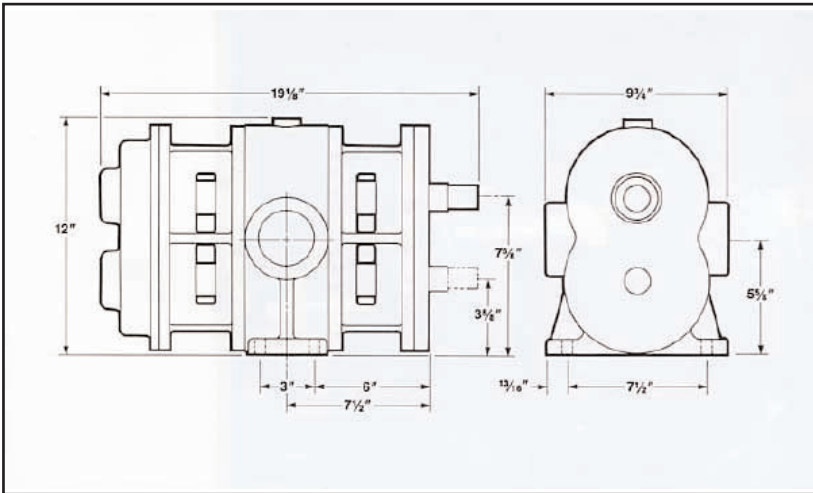

Average weight: 250#

## Performance Characteristics (standard duty):

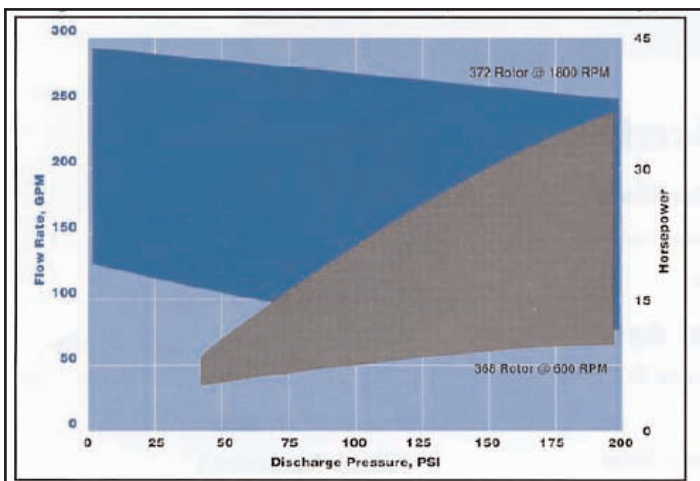

## Materials of construction

Ductile iron, bronze, stainless steel

## Options

Hydraulic drive bracket, flanges

## Sealing

Teflon lip seals or rubber bellows  
mechanical seals

## Temperature

200°F maximum

## Discharge pressures

Standard duty - to 200 psig  
Heavy duty - to 300 psig  
Extreme duty - to 450 psig

## Ports

3" x 3" NPT (female) standard

## Pump drives

Hydraulic, electric, gas or diesel  
engine, PTO

## RPM range

Up to 1,200 rpm continuous  
Up to 2,200 rpm intermittent

Edwards - Pentair Water manufactures pumps to adapt to existing or new drive equipment. We custom build complete pumping packages. Our expertise includes complete assemblies with motors, engines, pumping skids and electrical apparatus with controls. Please feel free to contact us regarding your requirements.



Pentair Water - North Aurora Operations

800 Airport Road • North Aurora, IL 60542 USA

Telephone: 630-859-7000 • Fax: 630-859-1226 • [edwards\\_info@pentairpump.com](mailto:edwards_info@pentairpump.com) • [www.edwardsmfg.com](http://www.edwardsmfg.com)

*Quality pumping equipment since 1926.*