

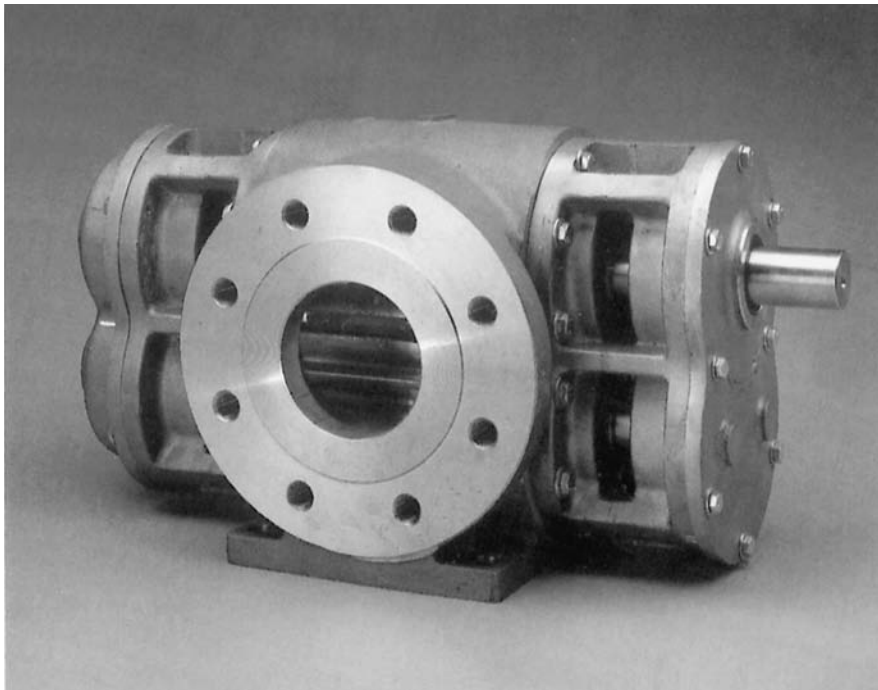

MODEL 400 PUMP



Features

The Edwards Model 400 Rotary Gear Pump has several unique features that make Edwards the right choice for many pumping requirements:

- Rotors synchronized by timing gears - they never touch
- Replaceable, casing liners
- Shafts are supported on both ends by bearings - not bushings
- Pump drive flexibility - direct drive in most cases
- Dry running capability
- Self priming

Applications

Fire Protection

- Fire-fighting foam concentrate
- Water mist pumps

Industrial Applications

- Bulk Unloading and Transfer
- Seawater or Brines
- Polymers, resins, glues
- Fuel Oil Transfer
- Deep Well Water Injection

Industries Served

- Trucking/bulk transfer
- Fire protection
- Pulp and paper
- General industrial
- Petro chemical
- Oil Field
- Marine fuel transfer

MODEL 400 PUMP SPECIFICATIONS

Approximate Overall Dimensions:

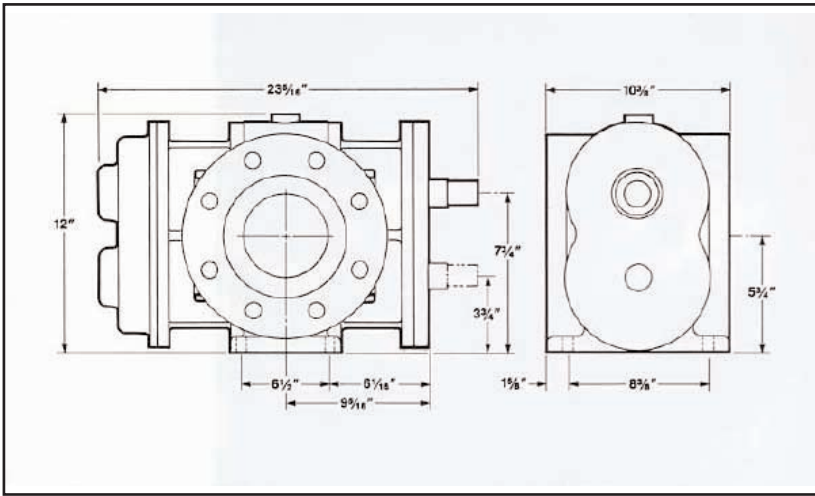

Average weight: 350#

Performance Characteristics (standard duty):

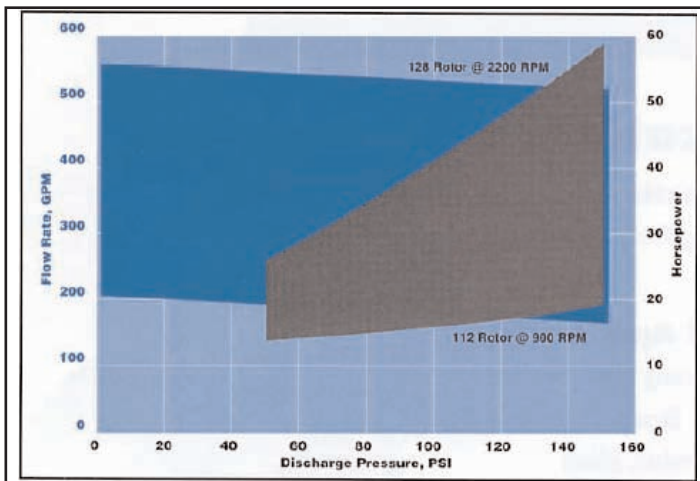

Materials of construction

Ductile iron, bronze, stainless steel

Options

Hydraulic drive bracket

Sealing

Teflon lip seals or rubber bellows
mechanical seals

Temperature

200°F maximum

Discharge pressures

Heavy duty - to 300 psig

Ports

4" x 4" 150# or 300# FLG

Pump drives

Hydraulic, electric, gas or diesel
engine, PTO

RPM range

Up to 600 rpm continuous
Up to 1,800 rpm intermittent

Edwards - Pentair Water manufactures pumps to adapt to existing or new drive equipment. We custom build complete pumping packages. Our expertise includes complete assemblies with motors, engines, pumping skids and electrical apparatus with controls. Please feel free to contact us regarding your requirements.



Pentair Water - North Aurora Operations
800 Airport Road • North Aurora, IL 60542 USA
Telephone: 630-859-7000 • Fax: 630-859-1226 • edwards_info@pentairpump.com • www.edwardsmfg.com

Quality pumping equipment since 1926.