

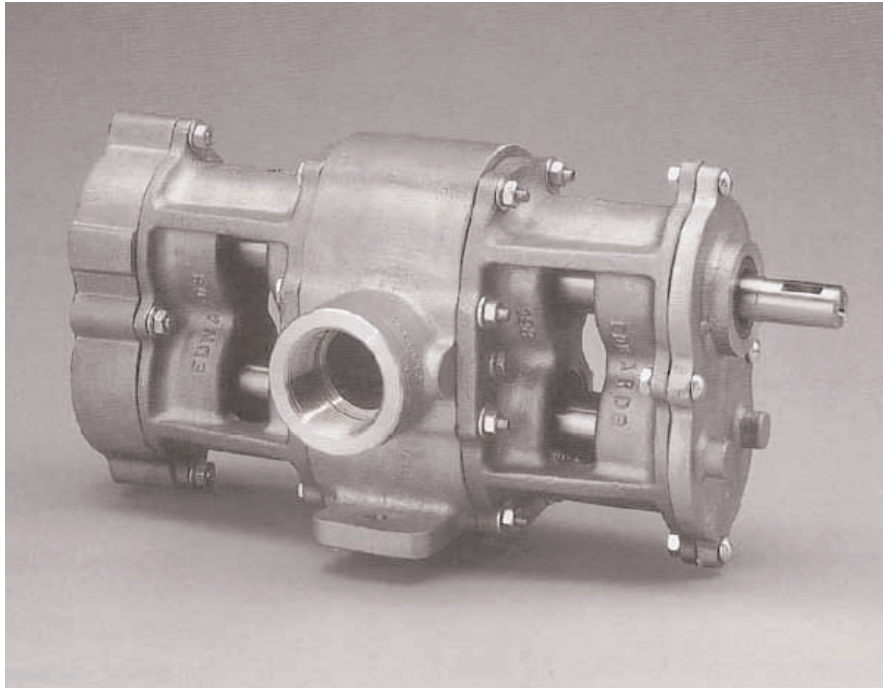

MODEL 80 PUMP



Features

The Edwards Model 80 Rotary Gear Pump has several unique features that make Edwards the right choice for many pumping requirements:

- Rotors synchronized by timing gears - they never touch
- Replaceable, casing liners
- Shafts are supported on both ends by bearings - not bushings
- Pump drive flexibility - direct drive in most cases
- Ductile Iron, bronze or Stainless Steel
- Dry running capability
- Self priming

Applications

Fire Protection

- Fire-fighting foam concentrate pumping
- Water mist pumps

Industrial Applications

- Thin viscosity fluids
- High pressure water
- Non lubricating fluids
- Chemical processing and transfer
- Machine coolant
- Polymer and Coatings
- Seawater or brine
- High pressure fuel transfer
- Additives

Industries Served

- Petro/chemical processing
- Food processing (non-sanitary)
- Fire Protection
- Pulp and paper
- General industrial
- Marine uses
- Oil field
- Mining

MODEL 80 PUMP SPECIFICATIONS

Approximate Overall Dimensions:

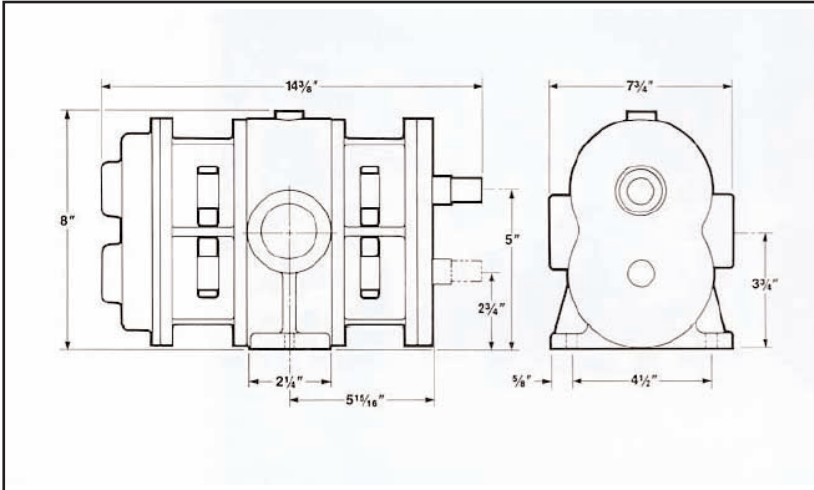

Average weight - Pump only: 57#

Materials of construction

Ductile iron, bronze, stainless steel

Options

Mixed internal materials, flanged connections, special mounting options

Sealing

Teflon lip seals or rubber bellows mechanical seals

Temperature

250°F maximum

Discharge pressures

Standard duty - to 200 psig

Heavy duty - to 300 psig

Performance Characteristics (standard duty):

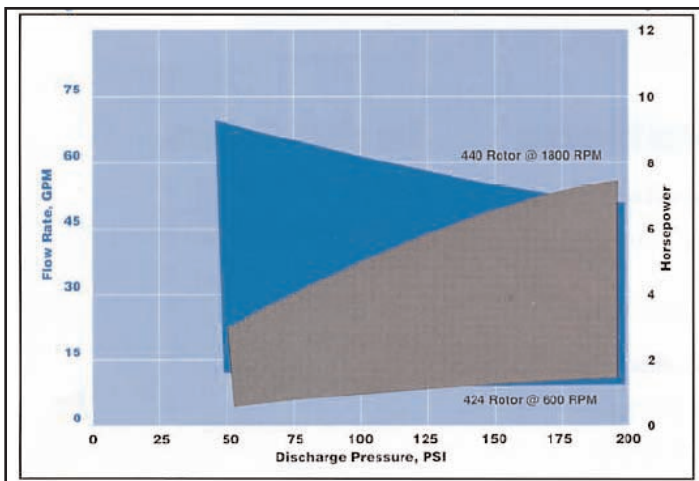

Ports

1-1/2" x 1-1/2" NPT (female) standard

Pump drives

Hydraulic, electric, gas or diesel engine, PTO, water turbine

RPM range

Up to 1,200 rpm continuous

Up to 2,300 rpm intermittent

Edwards - Pentair Water manufactures pumps to adapt to existing or new drive equipment. We custom build complete pumping packages. Our expertise includes complete assemblies with motors, engines, pumping skids and electrical apparatus with controls. Please feel free to contact us regarding your requirements.



Pentair Water - North Aurora Operations

800 Airport Road • North Aurora, IL 60542 USA

Telephone: 630-859-7000 • Fax: 630-859-1226 • edwards_info@pentairpump.com • www.edwardsmfg.com

Quality pumping equipment since 1926.